

the power to control

bachmann.

We speak Microgrid

Technology and expertise for
the future of energy management.



Each microgrid project is unique.

The selection of suitable components, the functional requirements and the perfect interaction are complex – **we guide you with our experience and our technologies to your best solution** – talk with us.

Expert workshop on your project plans: Get our expertise and recommendations on how to approach your project in a non-binding exchange. We will show you what requirements need to be met and which solutions we can offer. At the end, you will have an idea, concept and schedule for a successful implementation – openly, fairly, without any obligation.



Technology
+ Expertise
= **Success**

Contact us and benefit.

Microgrid and Energy Management

Open. Modular. Secure.

Microgrids are autonomous, intelligent power grids with the capability to operate independently of the public network. A microgrid essentially acts as a decentralized energy system that both connects to and disconnects from the main grid.

A microgrid consists of energy consumers, energy producers, and often energy storage units. Smart components are used to ensure energy balance and voltage stability. Microgrids are not limited by size – any self-sufficient power system can function as a microgrid.

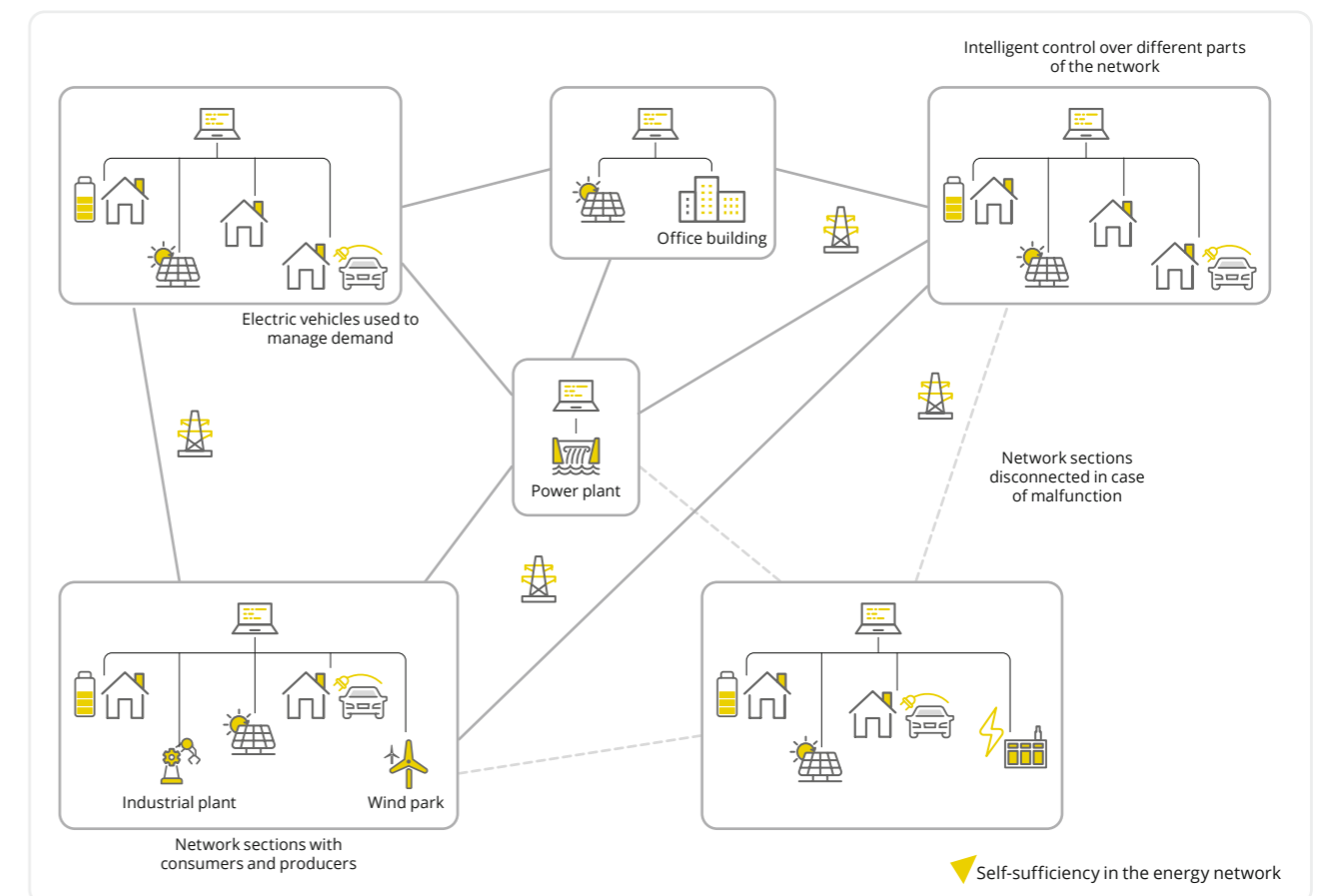



Secure

A microgrid offers multiple benefits, such as energy security in the event of power failure, as well as full, local control of the entire system.



Sustainable

Modern microgrids are usually powered by renewable energy sources such as wind, photovoltaic, hydro or CHP units, making them a sustainable and cost-efficient alternative to energy from the public grid, particularly when combined with energy storage facilities.



Smart

Microgrids usually rely on intelligent technological components, such as smart meters, which simultaneously turn them into self-sufficient smart grids. With this technology, energy from volatile power sources, such as wind turbines, can be easily and cost-effectively integrated into the power grid.



Our Role in your Microgrid

With over 50 years' experience in automation technology, Bachmann is the ideal partner for your independent energy ecosystem. Our controller technology provides the backbone for seamless operation, while our energy management modules in hard- and software deliver grid measurement, regulation and control powerfully and safely.

Which functional microgrid components do we provide?

The following products should be understood as a multitool for successful and secure microgrid energy management:



Open interfaces – fieldbuses and standard energy protocols



Application development in all languages – IEC 61131-3, C/C++ and MATLAB®/Simulink®



Solutions for energy supply – energy management



World of visualization – one SCADA software for all applications



Smart power plant controller – PGS controller, compliant with connection guideline VDE-AR-N 4110 for supply



Security integrated in the control system – multi-level IT security concept

These components and technologies provides flexible solution modules for a wide range of tasks within a heterogeneous microgrid. For the right mix and the best tool configuration, our expertteam is at your disposal – please don't hesitate to contact us.



Open Interfaces

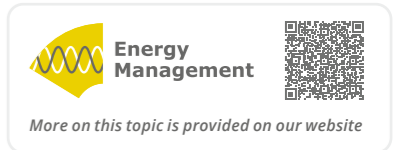

Fieldbuses and standard energy protocols

Growing requirements

The steadily increasing input of renewable energy sources into the grid also increases demands on communication: Continuous data exchange must be reliably guaranteed at all times – and always in compliance with all relevant norms and standards.

Perfectly served by Bachmann

With the Bachmann controller system, every internationally required telecontrol protocol for energy technology is

available as a software solution and can be easily installed. Additional hardware or changes to the plant management program are not required.

Customer specifications can therefore be implemented quickly and cost-effectively. Bachmann's controller is a true multi-talent: It can control external devices as a master and at the same time be integrated into a higher-level control system. It is also possible to operate different protocols on the same controller.

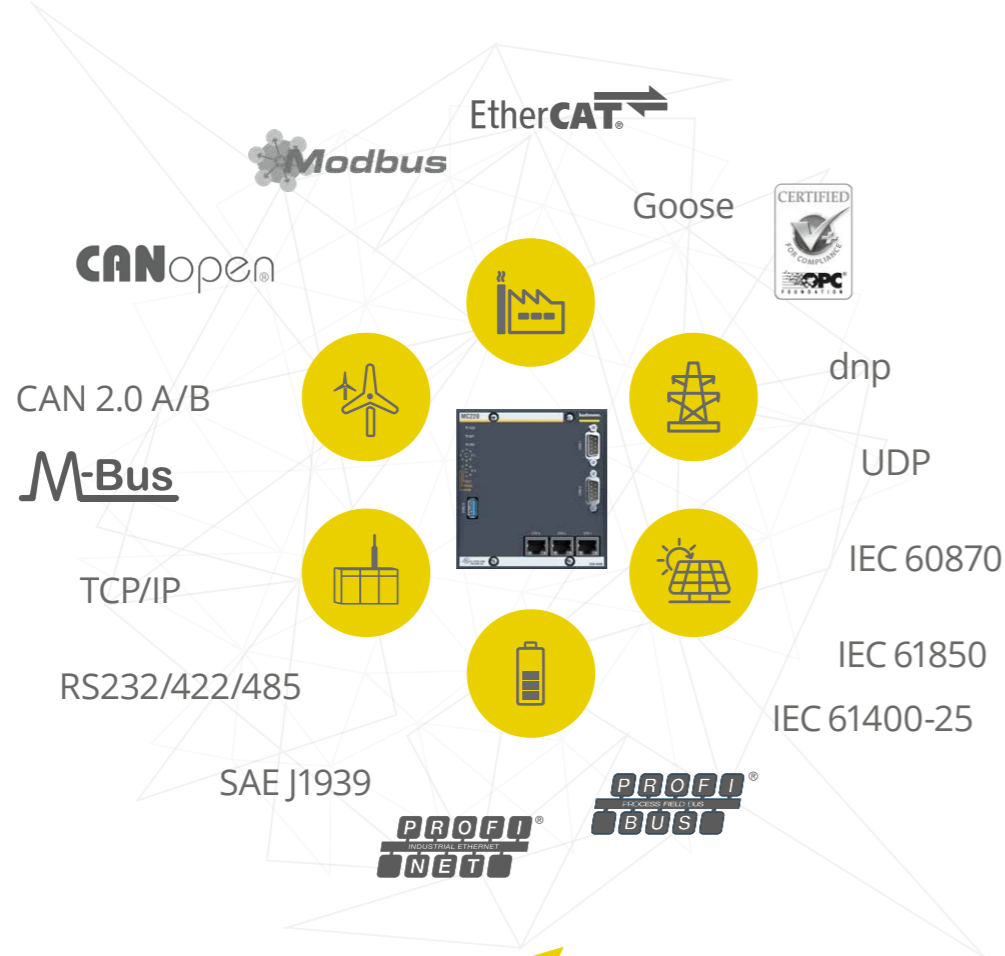

Open interfaces

- Problem-free integration of third-party systems and components
- Simple expansion of functions through the "eclipse market place"
- Reusability of existing functions through open operating system
- Free choice of protocol without changing the automation
- Plantwide data transparency in real time

Efficient energy park networking

- Free choice of protocol without changing the automation system
- Only one contact person for automation and communication
- Required protocol always available
- Ability to react flexibly and separate tasks
- Concentrate on the essentials: the core competence
- No need to store additional devices
- Higher availability due to a lean system

Solutions for Energy Supply

Energy management

The widespread use of electricity in all aspects of work and life offers a multitude of benefits, greater convenience and an improved quality of life. In order to ensure energy-optimized solutions in production, buildings and in infrastructures, there is a growing need for these to be based on suitable measuring systems. At the same time, the maintenance of supply security requires integrated solutions for operating grids and the standards compliant management of generating units. Bachmann offers both synergies through the direct integration in the PLC world as well as certified compliance with the latest regulations.

GM260

Grid Measurement Module



GMP232/x

Grid Measurement and Protection Module



GSP274

Grid Measurement, Synchronization and Protection Module



Application areas	GM260	GMP232/x	GSP274
Operational measurement	✓	✓	✓
Energy monitoring	✓	✓	✓
Power quality	-	✓	✓
Monitoring/grid connection	-	✓	✓
Protection function	-	✓	✓
Online fault diagnostics	-	✓	✓
Generator connection (synchronization)	-	-	✓



Smart Power Plant Controller



PGS controller, compliant with connection guideline VDE-AR-N 4110 for supply

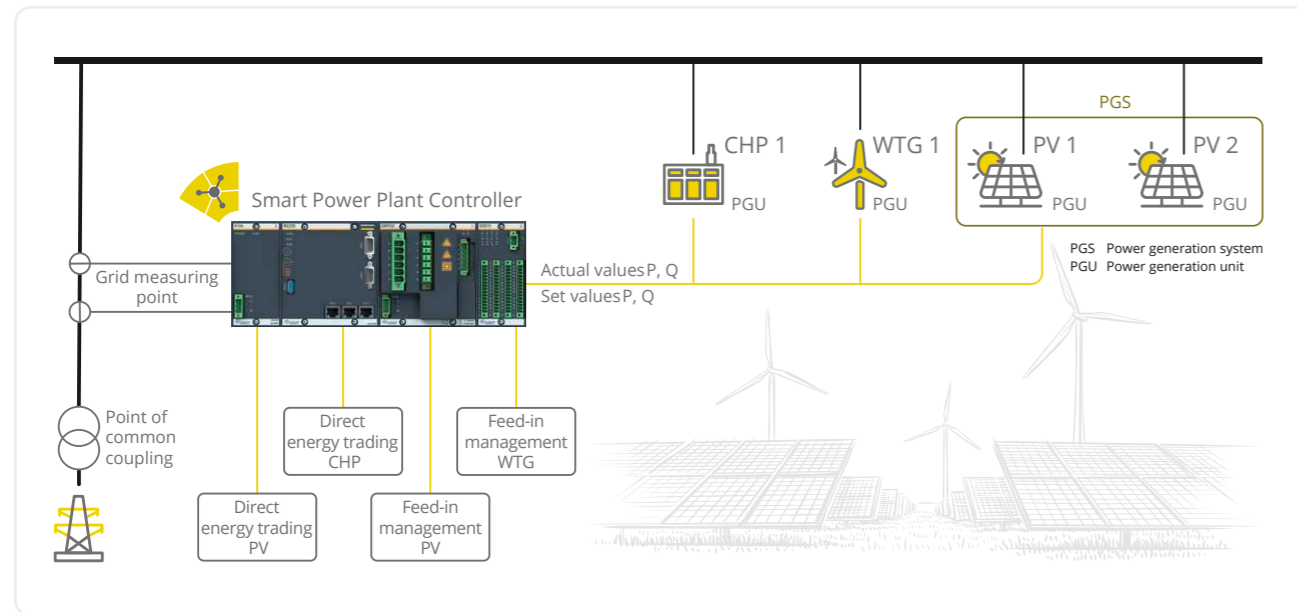

Example of a plant structure with smart power plant controller

To operate a power plant (PGS) efficiently, the power management at the point of common coupling (PCC) is very important. The power plant could consist of different generation units (PGU), which are represented by combined heat and power units (CHP), photovoltaics (PV), wind turbines or storage components. A given power value could be set either manually or from a third party, e.g. direct energy trading. The resulting set-point for the different generation units in the park is calculated by the controller and then supplied to the units. According to the new requirements, which are valid from May 2019, it is mandatory for every power plant producing a power input ≥ 135 kW, to have a certified power plant controller, which has implemented the functionalities and follows the required rules.

Bachmann electronic provides an PGS controller, based on the proven Bachmann CPU's and the extremely high accurate grid and measurement module (GMP232/x). In addition to this, it completely fulfills the connection guideline VDE-AR-N 4110 for power supply. The core component is the closed-loop-controller, which is a software module created by Bachmann with the extension M-Target for MATLAB®/Simulink®. This software module meas-

ures the values at the point of common coupling and with using the actual values from the park grid, it calculates the set-points and sends them to the different types of generation units.

All the required functionalities regarding set-points for active and reactive power, also the supply of these set-points towards the generation units, e.g. CHP, are implemented. To complete this product, a local HMI is also provided. It could be used for configuration, monitoring and operation.

This product is also shipped with a simulation library of the PGS controller for PC. This could be easily integrated into common grid simulator programs, which are normally used to certify the whole energy plant. To allow the access of direct energy trading (DET) or feed-in management signals (EINSMAN), Bachmann has the most common communication protocols already included, e.g. IEC 60870-5-101/104, IEC 61850 or Modbus. These are easily to configure and beyond this, digital or analog signals could of course be used. In addition, this PGS controller solution provides the highest standards according to security, which checks and logs each and every access and change of value.

Application Development in all Languages



IEC 61131-3, C/C++ or MATLAB®/Simulink®

Programming is an essential part of the engineering process. Any possibilities to save time in this development step in particular are therefore desirable. The combination of optimum technology for the particular task and helpful functions increases efficiency and improves code quality.

Model-based development with graphical simulation and programming environments are becoming increasingly established tools for complex tasks. These reduce complexity and ensure that the focus is on what is essential: optimum task implementation.

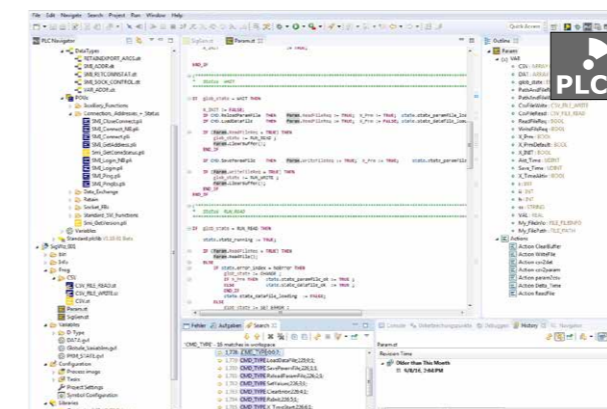
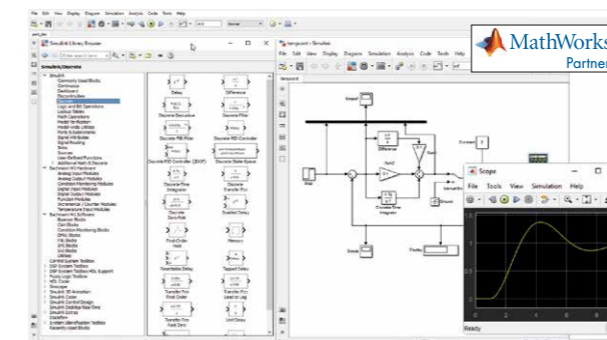

Equipped for the future

The SolutionCenter and the Bachmann controller support a wide range of programming languages: C/C++, all IEC 61131-3 languages and MATLAB®/Simulink®.

Programmers thus have the possibility to create applications in their familiar environment and language. Existing and established software code can also be reused without any problem. Libraries for PLCs can be created in all languages. The supported languages can also be combined as required.

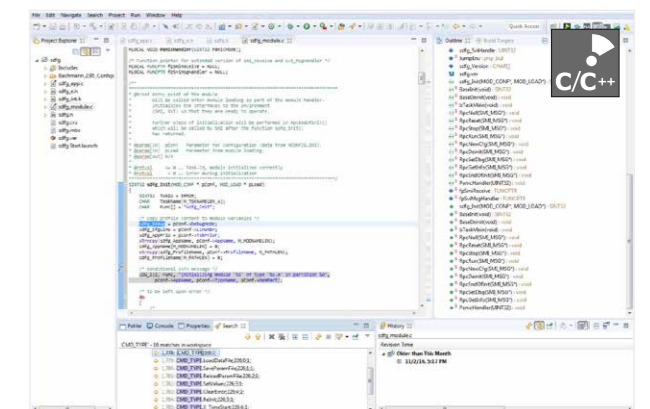

World of Visualization



— One SCADA software for all applications

M1 webMI pro

Native web technology used: M1 webMI pro makes it possible to use the advantages of web technologies entirely without restrictive add-ons such as browser plug-ins. All visualization devices from smartphones to powerful operator terminals can be connected, operated and monitored via a web server integrated directly on the Bachmann controller. Wherever and whenever the process requires it.

atvise® hmi

With the atvise® builder as an engineering tool with full graphic support, atvise® hmi offers everything needed for the rapid implementation of visualisations. In addition to an extensive object catalogue, drag & drop support and consistent object orientation, atvise® hmi users also have a fully integrated

responsive design framework at their disposal. Numerous prepared dynamizations, drag-&-drop support and high degrees of freedom in implementation enable both beginners and experts to use the atvise® hmi optimally.

atvise® scada

Bachmann's SCADA system offers a convenient and comprehensive system solution for web-based visualization projects. Maximum flexibility and openness ensure rapid implementation, good maintainability and the possibility to expand the installation efficiently. For example, the process values can be depicted fully according to the IEC 61400-25 interface. This not only simplifies internal communication but also provides external operators and energy companies with uniform access to the specific characteristic values.

▼ The Bachmann HMI product portfolio offers the right solution for any application in the highest quality and can be tailored to your specific requirements as needed.

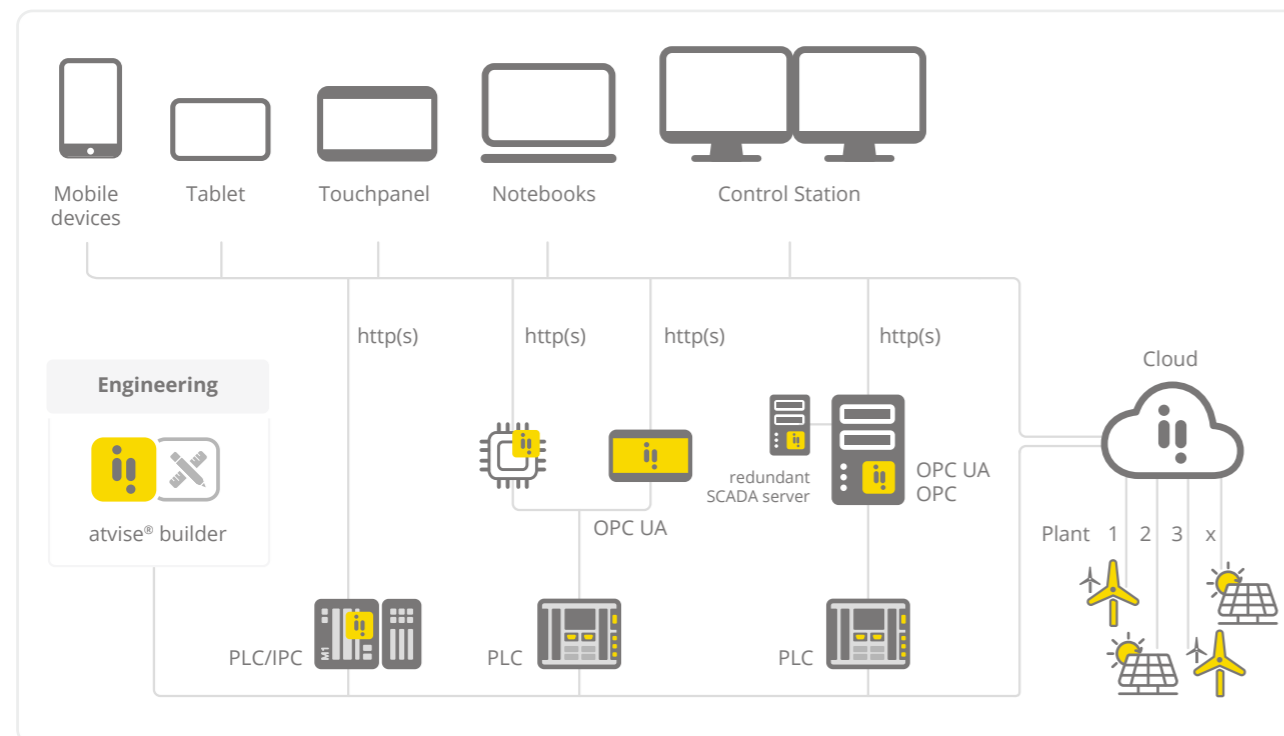

Security Integrated in the Control system

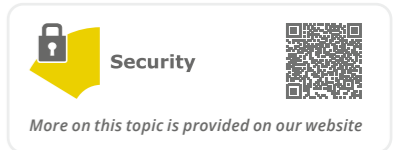

— Multi-level IT security concept

A selective security management system not only helps with unwanted and potentially destructive hacker attacks. Particularly in the protected environment of production plants, any accidental modification of machine parameters or configuration errors in the machine network are difficult to fully exclude. The effect of these, however, is often as serious as outside threats.



Level 1: Protected network

- Tap-proof data transmission through encrypted network connections
- Band width limitation to defend against overload attacks and for protection from faults in the network periphery



Level 2: Tap-proof communication

- Access control based on integrated user and password management
- Server and client authentication for the protection of automated teleservice accesses
- Secure end-to-end encryption to the latest state of the art (TLS 1.2)



Level 3: Authorized access control

- Rights are examined irrespective of the access path to the controller (visualization, SolutionCenter or with OPC UA)
- Restriction of system and execution rights for every user
- Role-based access control with groups (users inherit group rights)
- Configuration of access protection and visibility of files and process variables



Level 4: Hardened operating system

- The saving and running of additional applications can be prohibited
- Memory protection measures so that third-party processes cannot access the memory of the application
- Detailed logging of all user accesses with all user data and partition encryption



Level 5: Secure user applications

- Open interfaces to adapt and enhance all access control functions and for the use of cryptographic functions in applications
- Backup and recovery mechanisms
- Predefined security levels as templates for simple configuration

▼ **Security as standard:** Bachmann protects plants from production failure caused by unauthorized manipulation with a 5-level security concept. The entire Bachmann CPU product range comes with all security functions as standard. This therefore provides the user with an optimized ready-to-use security package.

bachmann.



www.bachmann.info

We speak Microgrid EN | Subject to alterations without notice
© 07/2024 by Bachmann electronic

